

(No Model.)

T. R. ALMOND.  
WIRE COILING DEVICE.

No. 531,673.

Patented Jan. 1, 1895.

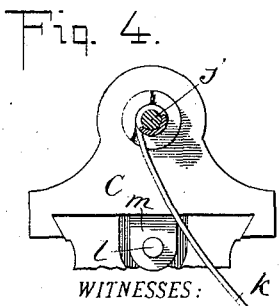
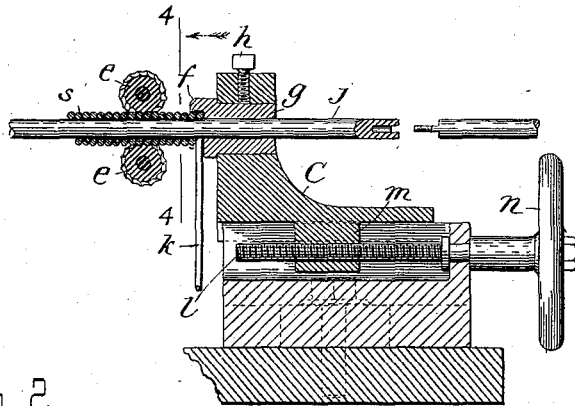
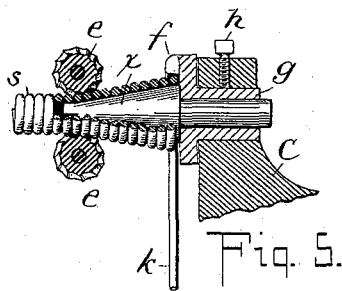
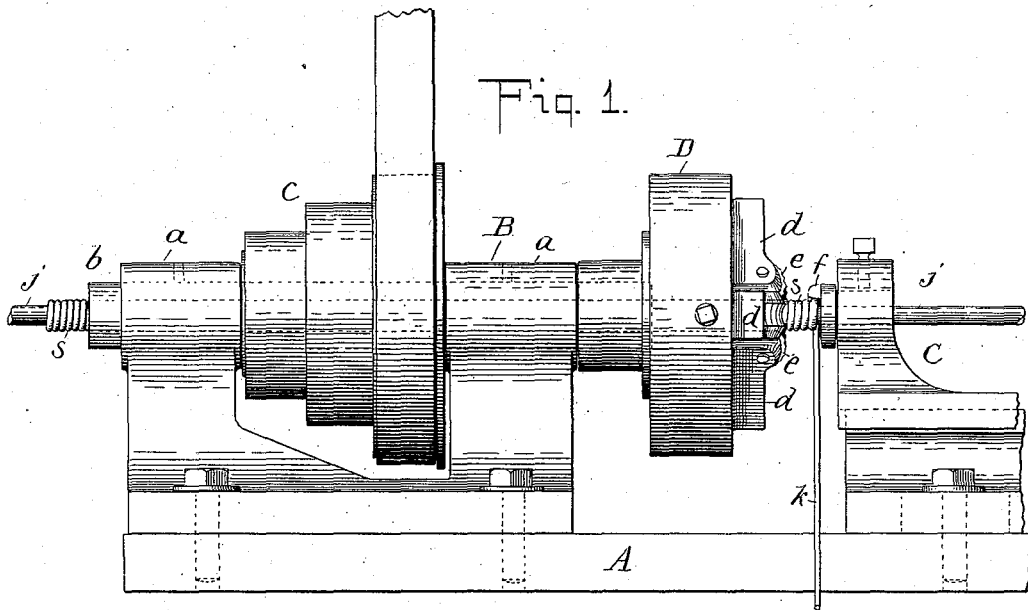

WITNESSES:  
*Prof. B. Steplund.*  
*Geo. E. Murray*

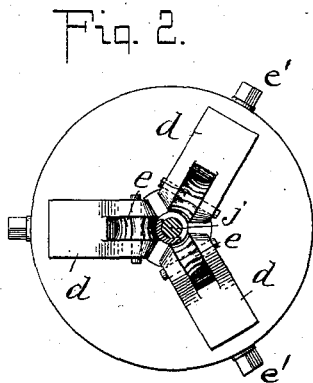

Fig. 3.  
INVENTOR  
*Thomas R. Almond,*  
BY *Briesen Knautz*  
ATTORNEYS

# UNITED STATES PATENT OFFICE.

THOMAS R. ALMOND, OF DUNWOODIE HEIGHTS, ASSIGNOR OF ONE-HALF  
TO WM. H. MILLER, OF BROOKLYN, NEW YORK.

## WIRE-COILING DEVICE.

SPECIFICATION forming part of Letters Patent No. 531,673, dated January 1, 1895.

Application filed June 5, 1894. Serial No. 513,505. (No model.)

To all whom it may concern:

Be it known that I, THOMAS R. ALMOND, a resident of Dunwoodie Heights, Westchester county, State of New York, have invented certain new and useful Improvements in Wire-Coiling Machines, of which the following is a specification.

My invention relates to wire coiling machines, and has for its object to produce an efficient wire coiling device which will coil wire into a very even spring, which can be run at a speed much greater than the ordinary machines built for this purpose, and which can be applied to any ordinary lathe.

To this end my invention consists in the construction hereinafter fully set forth and claimed.

Heretofore in machines of this character it has been customary to provide a mandrel carried in a rotating head upon which the spring was formed and pressure rolls carried in another rotating head, which pressure rolls were arranged to bear upon the spring as it was formed on the mandrel. These rolls, however, were mounted upon flexible arms projecting from the rotating head and no means were provided for preventing free outward movement of the rolls, that is to say, on account of the resiliency of the spring arms upon which the rolls were carried it was easy to spread the rolls apart, and hence with this class of machine the manufacture of a perfectly even spring was perhaps an impossibility owing to the fact that it was practically impossible with this structure to maintain the rolls at a constant distance apart. Hence, in the manufacture of springs of considerable length they would be of different diameters along different portions of their length which was very objectionable. Now by my invention I am enabled to obviate these and kindred defects and produce a helical spring of indefinite length and perfectly uniform in diameter.

My invention will be understood by reference to the accompanying drawings wherein—

Figure 1 is a side elevation of a machine embodying my invention. Fig. 2 is a face view of the chuck shown in Fig. 1, looking in the direction of the arrow in Fig. 3. Fig. 3 is a sectional view of the tail-stock of the

machine shown in Fig. 1, exhibiting the same in operation. Fig. 4 is a face view of the tail-stock, on the section taken on line 4—4 of Fig. 3, and looking opposite to the direction of the arrow. Fig. 5 is a broken away sectional view similar to Fig. 3 of another form of construction embodying my invention.

In the drawings, A is the bed of the machine.

B is a head-stock resting upon the bed A.

C is a tail-stock also resting upon the bed A and movable and adjustable thereon. This tail-stock may be of any suitable construction, but is preferably made in two sections movable relatively to each other for reasons which will hereinafter fully appear.

Carried in suitable bearings *a* of the head-stock is a hollow spindle *b* upon which is mounted a stepped pulley *c*. Carried also by the spindle *b* is a chuck D. This chuck may be of any suitable form of construction, but is preferably of the type known as a universal chuck, that is to say, a chuck having movable jaws, which jaws are controlled so as to move simultaneously and uniformly toward and away from the axial line of the chuck. The chuck may, however, be of any suitable form of construction and some of the jaws may be movable and some of the jaws fixed, the essential feature being that some means should be provided for holding the jaws in their adjusted position so as to prevent free outward movement of the jaws. Carried by these jaws are rolls *e* which are adapted and arranged to bear upon the coiled wire. These rolls may be grooved and corrugated as shown or simply grooved if desired. Mounted in proximity to the chuck and in operative relation thereto, as will be presently more fully set forth, is a former, shown in the present instance as a lug *f*, hung in a sleeve *g* and inserted in an aperture in the tail-stock C and rigidly held therein by a suitable binding or adjusting screw *h*.

The operation of the devices shown in Figs. 1 to 4 inclusive is as follows: A short length of the desired spring is first formed by any suitable means. The mandrel *j* is then inserted into this spring, and the spring and mandrel are placed in the chuck. The rolls are then brought down upon the spring which surrounds the mandrel and are tightened

upon it and securely held from free outward movement; that is to say, are held from being further separated by any suitable means, such as by the screws *e'*. (See Fig. 2.) The tail-stock carrying the former *f* is brought up and makes contact with the spring, the mandrel being allowed to pass freely through the tail-stock. The rolls grip the spring so firmly as to cause considerable frictional contact between the spring and the mandrel, so that upon revolving the spindle *b*, the spring *s* and the mandrel *j* will be caused to revolve with it and by virtue of the lug *f* and the fixed condition of the slide *C* a spring will be formed and will move forward through the spindle *b*, carrying with it the mandrel-*j*, which mandrel is rotated and moves forward with the spring as the spring is being formed; it, of course, being understood that as the chuck is rotated the remainder of the wire *k*, which is to form the spring, is allowed to pass freely into the machine and to be operated upon by the former *f*.

When the entire length of the mandrel has been covered, it is withdrawn, the pressure of the rolls having been released to permit of this. Another mandrel is then inserted through the tail-stock. The rolls are again brought down upon the spring and held as before from free outward movement, and the machine is set into operation, and the described operation for forming the spring repeated.

It will, of course, be understood that for different sizes of springs, the rolls, former and mandrel must be modified to suit. As for larger springs, a larger mandrel, former and groove in the rolls will be required.

I have shown the mandrel *j* as made in sections, as this is a very convenient form in which to have the mandrel. For different grades and kinds of wire it is often desirable to be able to adjust the former and the chuck relatively to each other and any suitable means may be adopted for such adjustment. I have, however, shown a screw *l* passing through a fixed part of the tail-stock (that is to say, a part which is usually adjusted on the bed and held in its adjusted position) and through a lug *m* mounted upon the movable part of the tail-stock. A hand-wheel *n* is provided for turning the screw *l*.

In Fig. 5 I have shown, instead of a mandrel extending through the coil, a tapering mandrel *x* carried by the tail-stock or any suitable support, and hung in proximity to the former.

The object of the tapering mandrel is to form a continuous spring without withdrawal of such mandrel as by virtue of the tapering form of the mandrel the spring will slide down its surface, there being no tendency for such a mandrel to move forward with the spring, as is the case with mandrel *j*. It will be seen that with such a mandrel a continuous spring will be formed without withdrawal

of the mandrel. This form of mandrel is best suited to springs made of lighter or weaker wire, or springs of larger diameter, as in such cases the roll pressure is considerably less. Time is saved by not having to withdraw a mandrel such as *j*.

For very strong springs, *i. e.*, springs of a small diameter formed of large wire, the use of mandrel *j* is desirable. The operation of this form of my invention (illustrated in Fig. 5) is in most respects similar to the operation of the form first described, the former serving to lay the wire upon the mandrel and the rolls serving to compress the coil and to feed the coil forward in the machine.

I do not limit myself to the precise construction and arrangement of devices herein shown, as the devices, their construction and arrangement, may be greatly varied without departing from the spirit of my invention.

What I claim, and desire to secure by Letters Patent, is—

1. In a wire coiling machine, the combination of a hollow head-stock, a rotating chuck carried thereby having rolls adapted to bear upon and to compress a spring, and means for preventing free outward movement of said rolls, of a tail-stock having a former mounted thereon and located in proximity to the chuck together with a mandrel free to rotate and to move longitudinally through the machine, the said mandrel passing through between the rolls and in proximity to the former, whereby the spring may be formed thereon and the spring and mandrel fed together through the machine, substantially as described.

2. In a wire coiling machine, the combination of a head-stock, a chuck mounted thereon carrying rolls adapted to bear upon and to compress a spring, a two-part tail-stock carrying a former located in proximity to the chuck, the parts of the tail-stock being movable relatively one to the other, substantially as described.

3. In a wire coiling machine, the combination of a chuck carrying rolls adapted to bear upon and to compress a spring, a two-part tail-stock carrying a former adapted to co-operate with the chuck to form a spring, the parts of the tail-stock being adjustable relatively one to the other, and means for adjusting the parts of the tail-stock relatively to each other, substantially as described.

4. In a wire coiling machine, the combination of a rotary chuck carrying rolls adapted to bear upon and to compress a spring, a tail-stock carrying a former adapted to co-operate with the chuck to form a spring, and a tapering mandrel hung loosely in the tail-stock so as to rotate freely therein and arranged to be rotated by the rotation of the spring in the process of forming the same, substantially as described.

5. A chuck carrying rolls adapted to bear upon and to compress a spring, the said rolls having peripheral and transverse grooves

therein, and means for preventing free outward movement of the rolls, substantially as described.

5 6. In a wire coiling machine, the combination of a head-stock, a chuck mounted thereon carrying rolls adapted to bear upon and to compress a spring, a tail-stock carrying a former located in proximity to the chuck, a mandrel freely movable in the direction of its

length passing loosely through the tail-stock in proximity to the former and arranged to be rotated by the rotation of the spring in the process of forming the same, substantially as described.

THOMAS R. ALMOND.

Witnesses:

HARRY M. TURK,  
GEO. E. MORSE.